

# Turn Yourself Loose on a Yamaha Synthesizer!

## CS-5

Yamaha introduces its most compact monophonic synthesizer that has many of the features and functions of the "big boys" but is still easy to use. The CS-5 has 37 keys by itself, something you might not expect in a synthesizer in this class, but with the 6-setting Feet (octave) selector switch, the instrument range is extended to a full 8 octaves. A Sample & Hold function permits you to automatically play a continuous random note. For the design and production of the CS-5, Yamaha use the technology that went into all its other synthesizer models. Just start playing this easy-to-use, portable monophonic synthesizer for yourself and you'll "feel" it's truly a Yamaha instrument. The CS-5 is a compact, quality synthesizer with an outstanding cost-to-performance ratio. You get

an awful lot for your money but it's up to you to use the CS-5 to its full potential.

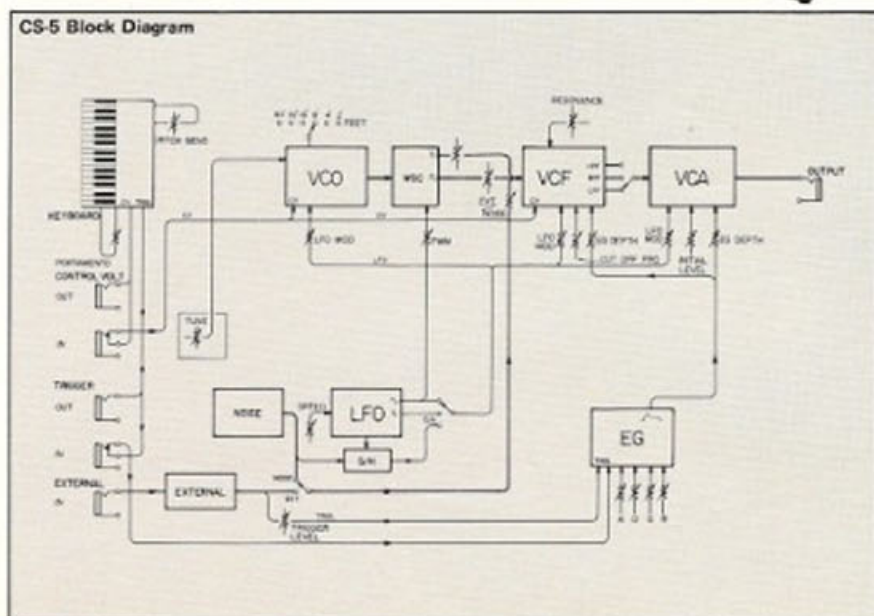

## CS-15

Yamaha's CS-15 includes 2 VCOs, 2 VCFs, 2 VCAs, 2 EGs and 1 LFO and is designed with an easy-to-see control panel layout that players will love. They're freed from complicated patch work and control is a snap with the one-touch knobs and switches. The sound sources are sawtooth wave, square wave, white noise and triangle wave for unique tonal characteristics. Two tones from the VCO 1 and VCO 2 can be freely combined and these can be detuned for special effects. The 2 EGs, with their reversed curves, perform the work of 4 EGs for greatly improved control of the VCF and VCA. In short, you get a lot more effects, control and versatility than you'd expect in this class of synthesizer. The PITCH BEND has a 3-stage LIMITER while the amount of harmonics (overtones) can be widely controlled with the BRILLIANCE lever. With the GLIDE section, fine nuances can be expressed by freely setting Depth and Time knobs. There's lots more to the CS-15 but we recom-

mend that you try it for yourself. Let it add a new dimension to your musical life.

